

## PERFORMANCE DATA SHEET NEMA PREMIUM NR CAN NEMA 12 - 12

Catalogue #: **MPP-17**

HP	kW	Voltage	S.F. @ 60Hz	EFF.	P.F.	Frame	Design	L.R. Amps
3	2,24	575	1,25	89,5%	0,77	182T	B	26

60 Hz								Code	F.L. RPM
FLA									
208	230	416	460	480	575	600		K	1760
/	/	/	/	/	3,2	/			

50 Hz								Code	F.L. RPM
FLA			S.F. @ 50Hz	Efficiency	Power Factor				
190	380	415				/	/	/	/
/	/	/							

Wgt. Lbs	PH	Duty	Insul. Class	Amb.	Elevation	Temp. Rise° C
97	3	Cont.	F	40°C	1000M (3300 Ft)	40

% Efficiency		% Power Factor		Torque		Winding Resist. Ω	Safe Cold Start (Secs)
Full Load:	89,5%	Full Load:	0,77	Full Load Ft/Lbs	9,0		
3/4 Load:	89,1%	3/4 Load:	0,70	Locked Rotor %	215		
1/2 Load:	87,6%	1/2 Load:	0,58	Break Down %	300		

Rotor Inertia Wk2 Lb-Ft2	Max Load Inertia Wk2 Lb-Ft2	Shaft Material	Frame Material	DE Bracket Type	ODE Bracket Type	Enclosure	NEMA Rating	Lead Wire Size
0,23	25	Standard	Cast Iron	Standard	Standard	TEFC	IP55	14 AWG

Ball Bearings		Grease	Mount Type	Orientation	Paint	Sound Pressure @ 3FT	Sound Power
DE	ODE						
6306	6306	Sealed Bearings	Rigid	Horizontal	Green	64	74

Inverter Duty.	Constant Torque Range	Variable Torque Range	Constant HP RPM
Motor meets MG1 parts 31.4.4.2	10:1	20:1	2700

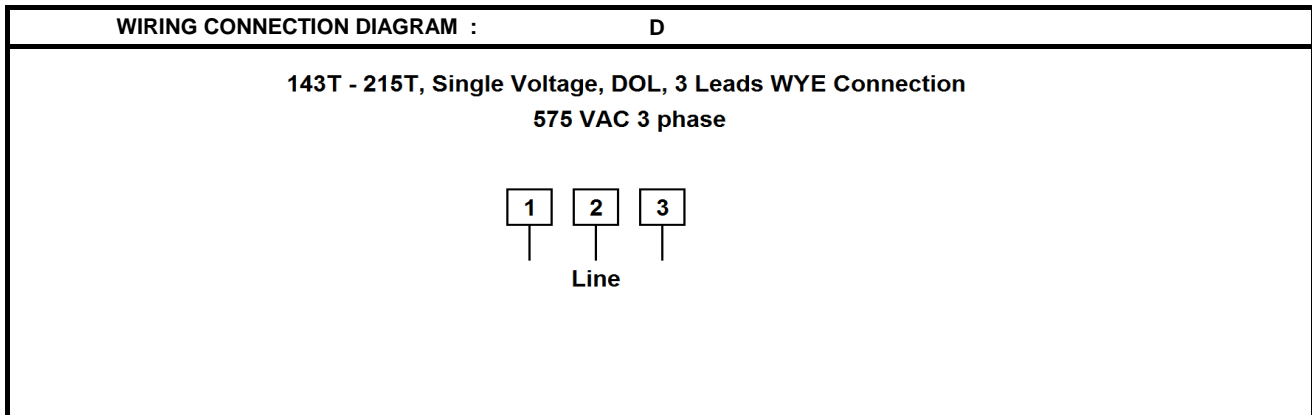

Date: 2020-02-27  
 Customer: \_\_\_\_\_  
 Contact: \_\_\_\_\_  
 Submittee: J.C. Lavallée

Catalogue #: **MPP-17**

NEMA PREMIUM NR CAN NEMA 12 - 12										
HP	VAC	RPM	Enclosure	Frame	Frequency	Design	Poles	LR Code Letter	Insulation Class	Temp. Rise °C
3	575	1760	TEFC	182T	60	B	4	K	F	40
	0Hz	6Hz	15Hz	30Hz	45Hz	60Hz	75Hz	90Hz	105Hz	120Hz
Amps	3,2	3,2	3,2	3,2	3,2	3,2	3,2	3,2	3,2	3,2
RPM	0	176	440	880	1320	1760	2200	2640	3080	3520
Torq ft.lb	7,16	8,95	8,95	8,95	8,95	8,95	7,16	5,97	5,12	4,48
Peak Tq ft.lb	11,19	22,38	22,38	22,38	22,38	22,38	17,90	14,92	12,79	11,19
HP	0	0,3	0,8	1,5	2,3	3,0	3,0	3,0	3,0	3,0
	Locked Rotor	Pull-Up	Breakdown	Rated Load	Idle	Duty	S. F.	Ambient	Elevation	dBA @ 1M
Speed (RPM)	0,0	756	1440	1760	1800	Continuous	1,25	40°C	3300 ft	64
Current (Amps)	26,0	22,1	15,5	3,2	1,7	VFD Rating: Meets MG1 parts 31.4.4.2				
Torque (ft-lbs)	19,2	14,4	26,9	9,0	0,0	C.T.	10:1	V.T.	20:1	

Motor Speed Data

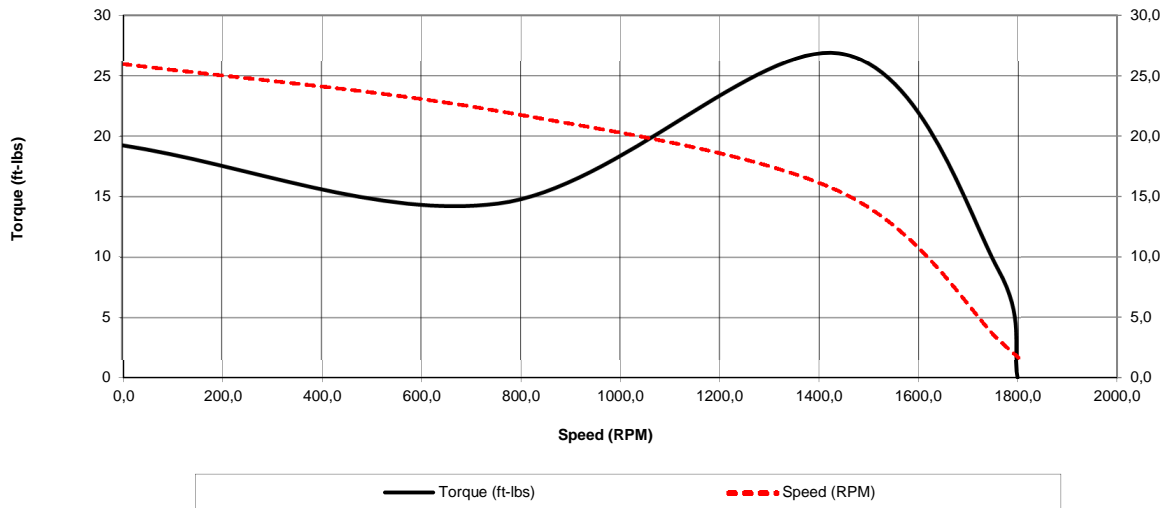

Motor Torque Capability vs RPM

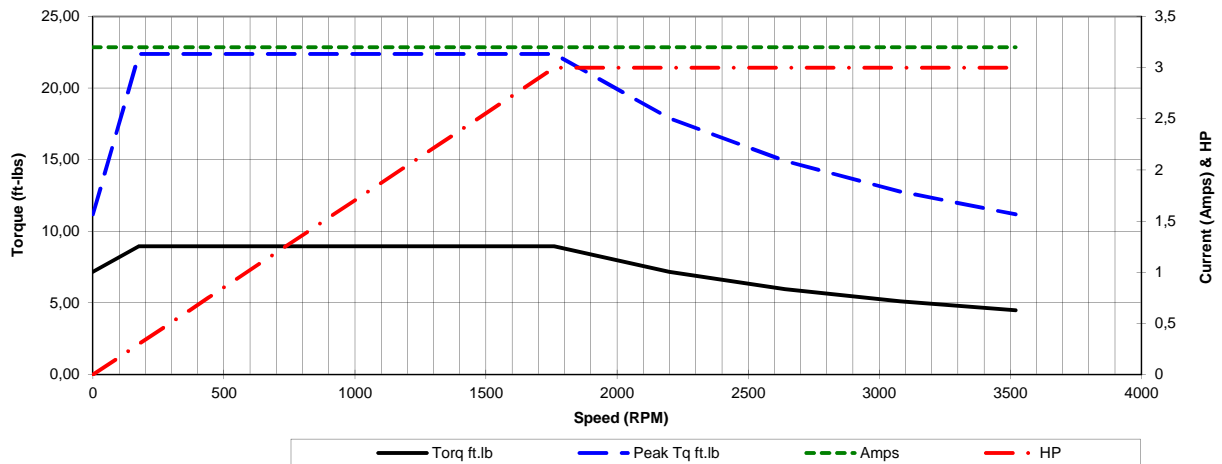



Date: 2020-02-27  
 Customer: \_\_\_\_\_  
 Contact: \_\_\_\_\_  
 Submittee: J.C. Lavallée

Catalogue #: **MPP-17**

NEMA PREMIUM NR CAN NEMA 12 - 12										
HP	VAC	RPM	Enclosure	Frame	Frequency	Design	Poles	LR Code Letter	Insulation Class	Temp. Rise °C
3	575	1760	TEFC	182T	60	B	4	K	F	40
<b>Load %</b>	<b>0%</b>	<b>25%</b>	<b>50%</b>	<b>75%</b>	<b>100%</b>	<b>125%</b>	<b>150%</b>			
<b>Amps</b>	1,72	1,95	2,22	2,72	3,20	3,95	4,69			
<b>Torq ft/lbs</b>	0	2,21	4,43	6,64	8,92	11,21	13,57			
<b>RPM</b>	0	1790	1780	1770	1760	1750	1740			
<b>Eff</b>	0	80,25	87,60	89,10	89,50	89,50	89,50			
<b>PF</b>	0	35,9	58	70	77	79,4	80,3			
	<b>Locked Rotor</b>	<b>Pull-Up</b>	<b>Breakdown</b>	<b>Rated Load</b>	<b>Idle</b>	<b>Duty</b>	<b>S. F.</b>	<b>Ambient</b>	<b>Elevation</b>	<b>dBA @ 1M</b>
<b>Speed (RPM)</b>	0	756	1440	1760	1800	Continuous	1,25	40°C	3300 ft	64
<b>Current (Amps)</b>	26	22,1	15,5	3,2	1,72	<b>VFD Rating: Meets MG1 parts 31.4.4.2</b>				
<b>Torque (ft-lbs)</b>	19,25	14,44	26,86	8,95	0,0	C.T.	10:1	V.T.	20:1	

